

FENCE LEGEND:

- x-x-x-x-x- 6' RESIDENTIAL FENCING
- 6' DECORATIVE PERIMETER FENCING

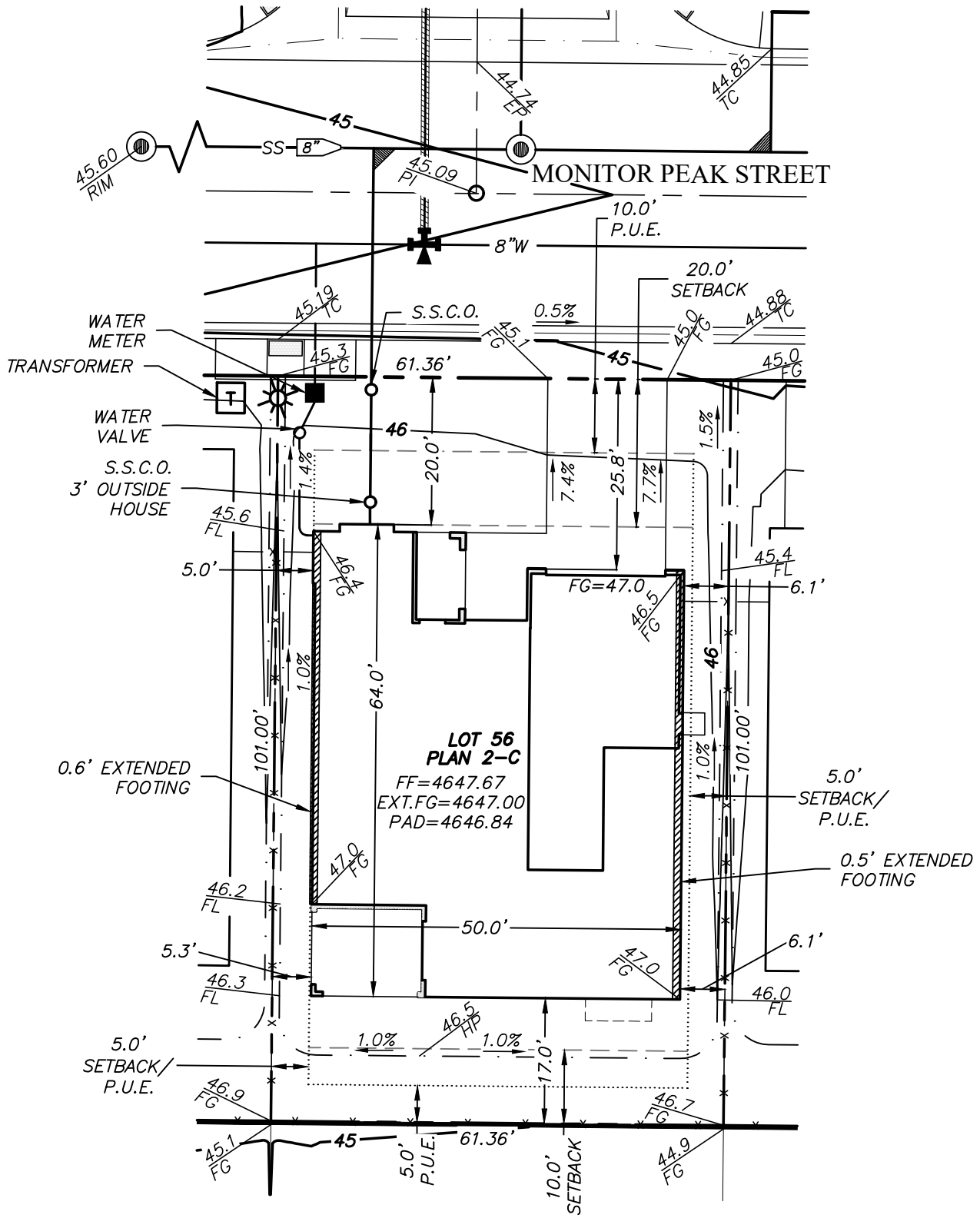

NOTES:

1. POSITIVE DRAINAGE SHALL BE PROVIDED AROUND ALL DOOR STOOPS. REF. ARCH. PLANS FOR LOCATIONS AND SIZING.
2. UTILITIES SHOWN ARE FOR REFERENCE ONLY. CONTRACTOR TO VERIFY LOCATION OF ALL EXISTING UTILITIES PRIOR TO CONSTRUCTION OF HOME.
3. ADD 4600 TO ALL SPOT ELEVATIONS.
4. SEWER BACKWATER VALVE IS NOT REQUIRED ON THIS LOT.

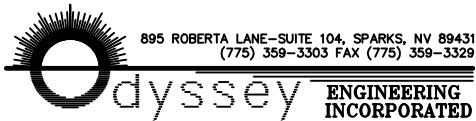

LOT NO. 56
 APN: 004-403-03
 LOT SIZE: 6,197 S.F.

PLOT PLAN FOR 1777 MONITOR PEAK ST. BLACKSTONE RANCH CARSON CITY, NEVADA

SCALE: 1"=20'
 DATE: 8-20-2021
 SHT. NO.: 1 of 1